



Product Specification instALERT Rapid Messenger Variable Message Sign

instALERT Display

- Open dimensions: 1 5/8" x 28" x 60"
- Folded dimensions: 3 1/4" x 28" x 30"
- Folded sign fits in police cruiser trunk, SUV hatch
- Full matrix display: 26 x 96 pixels, 0.6"x1" pitch
- LED pixels: Amber 595nm, 30 degree viewing angle, 100,000 hrs, black background, MUTCD compliant color, universal display modules
- On-board message selector buttons to select between 25 internal messages with anti-tamper lockout
- Power saving circuitry and automatic dimming for ambient light conditions with adjustable dimming range, Manual display brightness override
- Conformal coating on all circuit boards
- Integral case handles and nylon web handles
- Weight: 43 pounds
- Weatherproof, inherently sealed design
- 1/8" tinted, non-glare, UV stabilized polycarbonate face
- Entire face removable for service
- Aluminum chassis, 12 ga., with black powder coat finish
- Mounting provisions for permanent applications, (12) 1/4"-20 threaded holes
- -40 to 160 F operating temperature range, 95% humidity, non-condensing (-20F for Bluetooth comm.)
- Withstands 70 mph winds
- Meets MUTCD Specifications

instALERT Messages and Programming

- 1-3 line messages
 - 1 line: 24" H x 12.5" W characters, 4 per line
 - 2 lines: 10 1/4" H x 5.75" W characters, 8 per line
 - 3 lines: 7" H x 4" W characters, 12 per line
 - 2 lines: (1) 7" char, 12/line, (1) 10 1/4" char, 8/line
- Up to 3 screens per message
- Message power efficiency calculator in PC software
- Variable display time, flash and reverse rates for each screen
- Full graphics capability, each LED individually controllable, programmable from PC, PDA or remotely
- Ability to link multiple messages for up to 75 screen animation
- Scroll through 25 user defined onboard messages using selector buttons built into sign, no training necessary; buttons on unit become inactive after timeout to prevent tampering, reactivate by reapplying power
- Unlimited message storage on PC, PDA or remote server

- Messages on sign do not get erased when power removed
- Sign returns to last message when power applied
- Actual sign preview on PDA or PC controller
- Programming options:
 - Program custom messages with PC or PDA (optional)
 - PDA uses wireless Bluetooth communication.
 - Program from a safe location – up to 30' minimum
 - USB cable or Bluetooth from PC or Laptop using browser based PC interface
 - Remotely using Web-Based Remote Management



- Wireless PDA connection tools:
 - PDA connection easy to switch between multiple signs, automatically connects if one sign in vicinity locates and identifies sign to which connected
 - allows changing sign name
 - load instaMESSAGE using "Display Now" feature
 - load 24 messages into sign's memory
 - Scroll messages in sign's memory
 - Display signs from PDA memory
 - Manual display brightness override
 - Set automatic dimming range minimum and maximum levels
- Display battery level indicator on sign, PDA and/or PC
- Scheduling – 3 options to cover any need:
 - 1 day, 1 message: schedule the same message for up to 6 on time periods in a 24 hour day, repeats in each 24 hour cycle
 - 1 day, multiple messages: schedule up to 6 different messages for up to 6 different time periods in a 24 hour day, repeats in each 24 hour cycle
 - 7 day, multiple messages: schedule up to 6 different messages for up to 6 different time periods in a 24 hour day for each of 7 days, repeats in each 7 day cycle; up to 25 different messages can be used over the 7 day period
- all messages and scheduling reside on the instALERT – no external hardware necessary
- schedules can be saved on the PDA and PC for backup or for different events
- program schedule via PC program or wireless PDA



Product Specification instALERT Rapid Messenger Variable Message Sign

real time clock built into instALERT, time maintained with power disconnected
set time via PC program or wireless PDA
once enabled, schedule remains in action until disabled, even through a power interruption

- Stopwatch
Count up in time: hours, minutes, seconds, 1/100 seconds; up to 99 hours, 59 min, 59 sec
Count down in time, starting up to 99 hours, 59 min, 59 sec from end time; jump to full instALERT message at time = 0
Augment counter with text - 1 line of 12 characters
- Sign firmware field upgradeable
- Power cable customer replaceable, gold plated connector contacts, high visibility yellow cable
- Low battery indicator on sign, auto recovery with solar

instALERT Sign Power

- 10-28VDC input, 12VDC typical input, 8A max @12VDC (96 Watts max)
- 12VDC locking plug, 30A Capacity
- Compatible Power Supplies include:
Vehicles' power port, with optional adapter
Trailer wiring adapter for hitch mount
POWERcase portable power supply, PC26 or PC36
120 or 220 VAC Power supply in NEMA 4 enclosure with voltage and 10kA current surge suppression, short circuit protection and isolation transformer
ATS 5 Trailer (batteries with optional solar assist)

Standard instALERT System Components

- instALERT Variable Message Sign
- Padded carrying case with accessory pockets
- Browser based programming software for PC control
- USB cable for connection to PC
- Shoulder strap
- instALERT mounting bracket
single person deployment
mounts to pole or any surface using any hardware, no tools required
patent pending protected tamper resistant hardware compartment
rotate bracket for additional 12" of mounting height
aluminum with black powder coat
sign can be locked into bracket
sign can be bolted to mounting bracket for additional security
- Mounting hardware supplied

instALERT Mounting Options

- ATS 5 Trailer (refer to ATS 5 specifications for more info)
- Hitch mount
Sign height: 25" to bottom, 53" to top of sign from receiver tube (final height dependent on receiver height, flip mounting bracket for an additional 12")
Fits 1 1/4" or 2" receiver, adapter included
1/2" hitch pin
Locking rotation adjustment on 15 degree increments over 180 degrees,
+- 5 degrees tilt to adjust LED aim for maximum brightness
White powder coat finish with rear reflector
Not intended for operation above 15 MPH
- Telescoping Hitch Mount
All features of standard hitch mount, plus
Sign height: 53" to bottom, 81" to top of sign from receiver tube (final height dependent on receiver height, flip mounting bracket for an additional 12")
- Standard Portable Post: 42" to 55" to bottom, 70" to 83" to top of sign depending on leg positions, rotate bracket for additional 12"
- Large Portable Post: 72" to bottom, 100" to top of sign
- Pickup truck or Utility body rotating mount

Optional instALERT Sign Components and Features

- Internal radar allowing for speed dependent messaging and speed data collection – see Speed Dependent Messaging and Speed Display Data specifications
- Web-Based Remote Management Option
Message management
Remote configuration of settings
Tracking of equipment and status on map
Alerts for tampering and low battery
Full extended warranty with full remote suite
With internal radar option:
Data Management Service
Automatic data upload
Data analysis from all data collected over time, allows comparisons of multiple locations on multiple format reports
Alerts for high speed events and congestion
- PDA Controller with Pocket ATS software
PDA can be stored on board trailer
- On-Board time clock
- Password protection for remote message and connection software
- Fully compatible with Speed Dependent Messaging System when used with a SPEEDsentry or Shield Speed



Product Specification instALERT Rapid Messenger Variable Message Sign

Display - see Speed Dependent Messaging Specifications

- High Density Display with 52 x 116 pixels, 0.5" x 0.5" pitch
Chinese Language Programming, with high density display and Chinese entry on PDA or PC. 1, 2 or 3 line display of Mandarin Chinese Characters;

Warranty

- 1 year warranty
- Premier Care option (1 year and 3 year options)
 - Warranty service fully covered
 - Product software upgrades free
 - Product hardware upgrades at 50% off list price
 - Vandalism and accidental damage (non-warranty) at 50% off list price

Made in the United States of America



Product Specification instALERT Rapid Messenger Variable Message Sign

instALERT Dimensions, Open

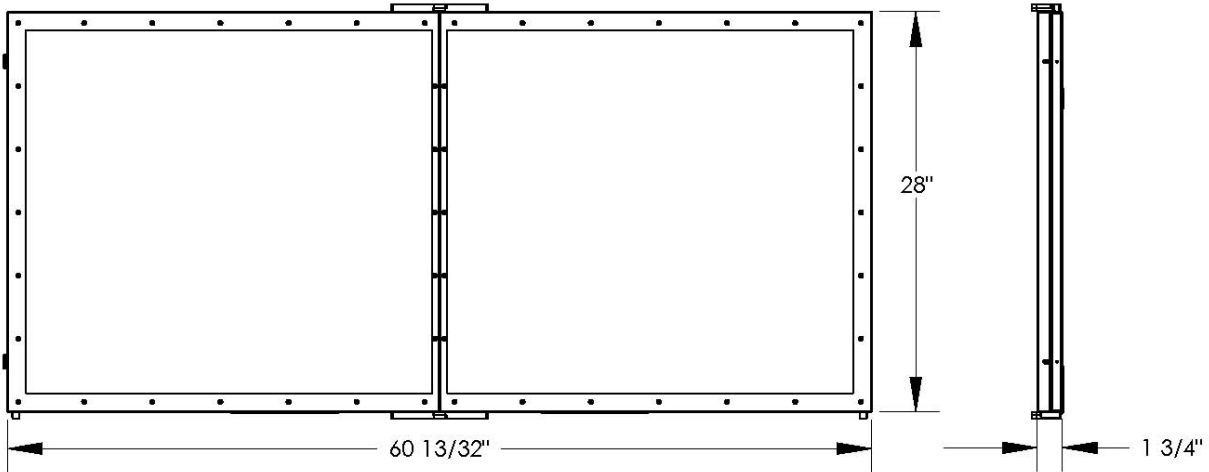

instALERT Dimensions, Folded

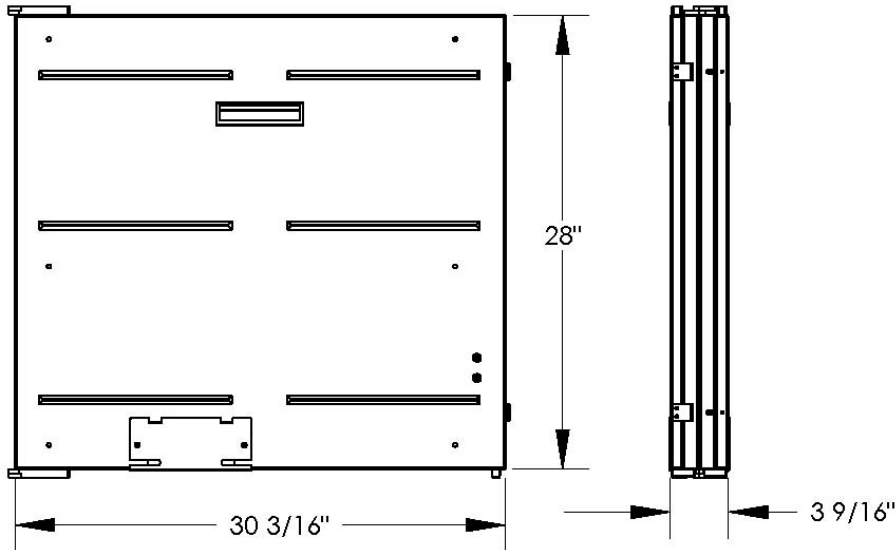

Mounting Plate Dimensions

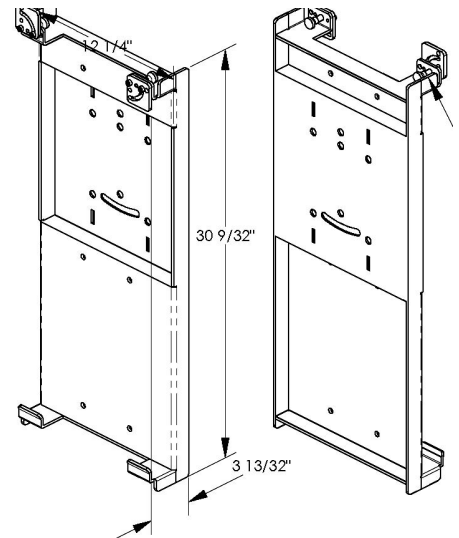

Mounting Hole Positions

