

## PRODUCT SPECIFICATIONS

# INSTALERT 48 CONTRACTOR-GRADE LARGE FORMAT MESSAGE BOARD FULL-MATRIX AND THREE-LINE

**ALL TRAFFIC**  
SOLUTIONS



- Easiest programming in the industry
- Capacitive touchscreen controller
- Intuitive interface with large buttons
- Safer programming at eye level
- Multi-level password protection
- Out of reach of the casual hacker
- Better traffic visibility
- Less external wiring
- NTCIP compliant
- Durable powder-coat finish, custom colors available
- Standard tow hitch and removable drawbar

- Low power consumption and more uptime
- Solar-charged deep-cycle batteries
- Cooling fans overheat protection
- Standard 15-amp AC charger included
- Energy efficient and superior performance
- Preprogrammed, custom and MUTCD graphics
- 360° display rotation for optimal positioning
- For optional equipment, contact factory



In-Cabinet Controller  
*(location shown)*



# The safest means for notifying motorists of changes in traffic patterns and road conditions.

Instalert 48 Contractor-Grade Message Signs are the ideal choice when you need to get information to the public. Mini-size signs provide versatility and great performance.

Full-matrix signs provide the greatest flexibility for displaying any type of message—large or small letters, symbols, graphics. Graphics and text can be combined in the same message. Three-line message signs are capable of displaying three rows of alphanumeric characters. The ultra-bright, highly legible LEDs display your message clearly.

Changing the message is simple, as Instalert 48 Contractor-Grade signs feature the easiest programming in the industry. The in-cabinet controller has a 7-inch LCD capacitive touchscreen. Signs come configured with preprogrammed standard messages. A quick-message function provides for display of select messages with a keystroke. Multiple programming options provide flexibility for multiple applications.

Unsurpassed quality, engineering and value, paired with a multitude of functions and options, make these signs perfect for a wide variety of applications.

**Meets NEMA TS 4-2005 Section 2 for ambient temperature, vibration, shock, electro-static discharge (ESD) and radio interference.**

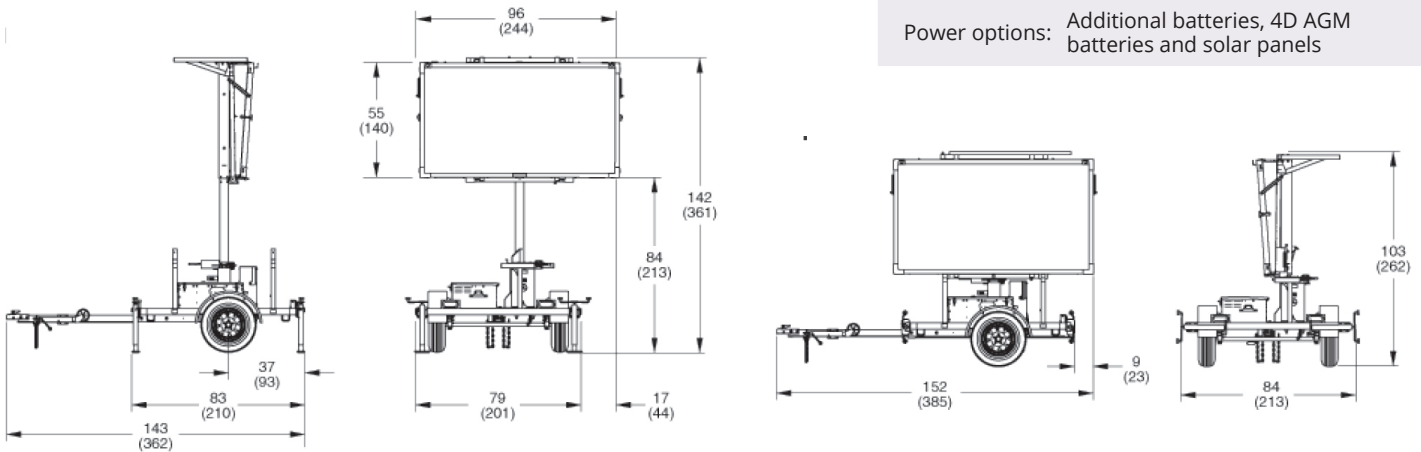

## FULL-MATRIX SIGNS

WVTM(A): Hydraulic lift

WVTM(B): Manual winch

Resolution: Four amber LEDs form each pixel

Font: 1 font

Default font: 5x7 pxls 3 lines of 8 characters max.

Font size: 9 x 14 in. (24 x 34 cm)

Batteries: Four 6 Vdc deep-cycle batteries wired for 12 Vdc power

Battery capacity: 430 Ah total capacity @ 12 Vdc

Solar panels: 85W minimum

Power options: Additional batteries, 4D AGM batteries and solar panels

## THREE-LINE SIGNS

WVTM(A): Hydraulic lift

WVTM(B): Manual winch

Resolution: Four amber LEDs form each pixel

Matrix: 48 pixels wide, 27 pixels high

Font: 12 fonts, selectable

Default font: 5x7 pxls 3 lines of 8 characters max.

Default font size: 8 x 12 in. (21 x 30 cm)

Batteries: Four 6 Vdc deep-cycle batteries wired for 12 Vdc power

Battery capacity: 430 Ah total capacity @ 12 Vdc

Solar panels: 85W minimum

Power options: Additional batteries, 4D AGM batteries and solar panels

### All Traffic Solutions

12950 Worldgate Drive, Suite 310, Herndon, VA 20170

P. 866-366-6602 E. [sales@alltrafficsolutions.com](mailto:sales@alltrafficsolutions.com)

©All Traffic Solutions

**ALL TRAFFIC**  
SOLUTIONS

**REQUEST A QUOTE NOW**

