



PRODUCT SPECIFICATIONS:

INSTALERT 18 VARIABLE MESSAGING SIGN

InstAlert Radar Message Sign

- **InstAlert 18 (IA18):** 45.7 x 71.1 cm full matrix
(InstAlert 24 (IA24) 61 x 152.4 cm full matrix also available – see separate InstAlert 24 Spec Sheet)
- Size and weight without battery
 - o 76.2 x 50.8 x 7 cm, 13.2 kgs
- Full matrix display
- **Universal mounting system:** Attach to pole, trailer or vehicle hitch mount
- Meets MUTCD Specifications

InstAlert Operation Modes

- **Message Mode:** Display one message, up to six screens
- **All Messages:** Sequence all messages in sign memory
- **Schedule:** Change message and/or mode up to 13 times/day
- Sign returns to last configuration when power applied

InstAlert Programming Methods

On-Board Programming (standard on all units)

- Select operation mode
- Select message from sign's memory

TraffiCloud™ Web-based Remote Management Services:

Remote Management using integral cell modem
(See TraffiCloud specification for more information):

- Turnkey system. Remote connectivity functional upon ship. Unit connects to TraffiCloud Service when sign powered
- Fully hosted web-based management system
 - o Internet connected computer with browser provides anywhere access on all connected devices with browser
 - o No IT involvement or support necessary. System bypasses customer network, eliminating access issues
 - o Cellular provided by ATS, no separate cellular charges
 - o Hosted database requires no setup or maintenance by customer

Apps – All apps included in TraffiCloud Message Suite:

- **Equipment Management:** Online sign management —Change messages and settings remotely
- **Alerts:** Notifications for low battery and tampering
- **Mapping:** Visually manage equipment and data
 - o PremierCare perpetual warranty

All Traffic Solutions PC Sign Manager

Local Management using PC with USB connection standard with all signs, Bluetooth optional

- PC-based client software
- Connect to sign via USB or Bluetooth (optional)

All Traffic Solutions Android App: Local Management (Optional):

- Android OS wireless Bluetooth control local to unit
- Android device can be phone or WiFi device with Bluetooth

Local Management Features: (PC and Android)

- Create and change messages and settings
Manage all unit settings, automatic sync with
- TrafficCloud Web-based Remote Management Service if subscribed
- All messages saved for online management and backup
 - o Create message and save to TrafficCloud library, messages available on all Android App or PC Sign Manager devices with TrafficCloud subscription

InstAlert Messages

- **IA18:** 1-2 line messages
 - o **1 line:** 26 cm H x 14.6 cm W characters, four per line
 - o **2 lines:** 17.8 cm H x 10.2 cm W characters, six per line
- Up to six screens per message
- Full graphics capability, each LED individually controllable
- Variable display time, flash and reverse rates for each screen
- Scroll through 25 user defined onboard messages using selector buttons built into sign, no training necessary
- Ability to sequence messages for up to 144 screen animation
- Message power efficiency calculator in software
- Actual sign preview and unlimited message storage using TrafficCloud Web-based Remote Management Service, All Traffic Solutions PC Sign Manager or Android app
- Messages on sign retained when power removed
- Sign returns to last message when power applied
- Conditional Messaging – Dynamically display messages driven off sensors and/or incorporate into messages

InstAlert Programming

Configure the following parameters via TrafficCloud Web-based Management System, Android App or PC Sign Manager

Messages

- o Create and load message using 'Display Now' feature
- o Load 24 messages into sign's memory
- o Scroll messages in sign's memory
- o Display signs stored in TrafficCloud Web, All Traffic Solutions Android App or PC Sign Manager

Scheduling

- **All Days, Multiple Messages:** Schedule up to 50 different messages or modes for up to 13 different time periods in a 24 hour day, repeats in each 24-hour cycle
- **Seven Day, Multiple Messages:** Schedule different messages or modes for up to 13 different time periods in each 24-hour day for each of seven days, repeats in each seven day cycle; up to 50 different messages can be used over the seven day period
- All messages and scheduling reside on the sign – no external hardware necessary
- Program schedule via TrafficCloud Web, All Traffic Solutions Android app or PC Sign Manager, save to load onto multiple signs
- Internal real-time clock, time and schedule maintained with power disconnected

Construction

- **LED Pixels:** Amber 595nm, 0.52 rad viewing angle, 100,000 hours, black background, (MUTCD compliant)
- **LED Density:** 1.5 x 2.5 cm pitch, 18 x 48 pixel matrix
- Conformal coating on all circuit boards
- Integral handle
- Weatherproof, NEMA 4, IP65 sealed
- 0.6 cm Tinted, non-glare, UV stabilized polycarbonate face
- Drip proof, vented battery compartments (2)
- Aluminum chassis, 14 ga, white powder coat finish, black powder coat front for maximum contrast for display visibility
- Tamper-resistant mounting hardware system, hardware, controls and battery access secured behind enclosure lock
- -40°C to 71°C operating temperature range, 95% humidity non-condensing (-29°C for Bluetooth communication, -15°C for internal camera)

InstAlert Power

- **Power Input, Max:** 12 VDC, 3 A max, 36 W max
- Power saving circuitry and automatic dimming for ambient light conditions with adjustable dimming range and manual display brightness override
- **InstAlert 18 Power Options:**
 - o 16Ah LFP battery with built-in short circuit and reverse polarity protection circuitry; 1.5A 12.8 VDC output, 120VAC input automatic charger; Capacity for up to 2 batteries in unit for extended portable use
 - o Solar panel assist: 40W or 60W solar panel and bracket, Solar controller panel with 26Ah lead acid battery; 6A 120VAC automatic charger optional
 - o 100-220VAC AC power supply (6A 12VDC) in external NEMA 4 enclosure

Mounts on pole, stand, vehicle or ATS Trailer

Engineered and manufactured in the USA

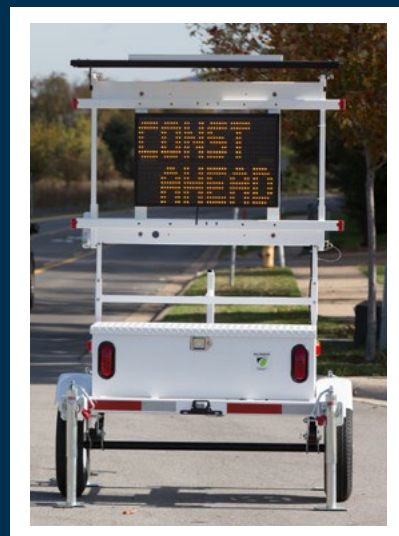

- o ATS 5 Trailer (batteries with optional solar assist: 235 or 470 Ah battery system, 40 or 60W solar option)
- o ATS 3 Trailer, 100Ah battery and 40W solar option
- Battery level indicator on sign, All Traffic Solutions Android App, PC Sign Manager or TrafficCloud Remote Management
- Auto recovery for battery with solar

Standard InstAlert System Components

- InstAlert Variable Message Sign IA18
- Tamper-resistant mounting plate and hardware
- Key
- On-board controls
- PC Sign Manager software with USB cable

Optional InstAlert Components and Features

- TrafficCloud Web-Based Remote Management Service
- All Traffic Solutions Android app, Bluetooth connectivity
- Padded carrying case
- Extra mounting brackets
 - o 7A, 30VDC or 7A 120VAC max, 100mA 5VDC min, no power supplied, simply a contact closure
- Tamper Alarm: ATS 5 or ATS 3 Trailer

InstAlert Mounting Options

- Pole mount standard with included bracket, hardware

- NCHRP 350 approved on 10.2 cm pole (Letter SS-135)
- ATS 5 Trailer (refer to ATS 5 specifications for more information)
- ATS 3 Trailer (refer to ATS 3 Trailer specifications for more info)
- **Vehicle Hitch Mount**
 - o Mounts sign 76.2 cm to bottom of sign from receiver tube (final height dependent on receiver height)
 - o Fits 3.2 or 5.1 cm receiver, adapter included, 1.3 cm hitch pin
 - o Locking rotation adjustment on 0.3 rad increments over 3.14 rad, +/- 0.1 rad tilt
 - o White powder coat finish with rear reflector
- **Standard Folding Portable Post**
 - o Folds for easy storage and portability
 - o **IA18:** 152.4 x 185.4 cm to bottom, 203.2 x 236.2 cm to top of sign depending on leg position
- Mounting provisions for permanent applications with ¼-20 threaded holes

PremierCare Warranty

- 1-year warranty (three months on Li-Ion batteries)
 - o Product software upgrades free
- PremierCare included with TrafficCloud Web Subscription
 - o Perpetual warranty for the duration of subscription
 - o Accessories, vandalism and accidental damage (non-warranty) at 50% off list price

InstAlert 18 Mounting

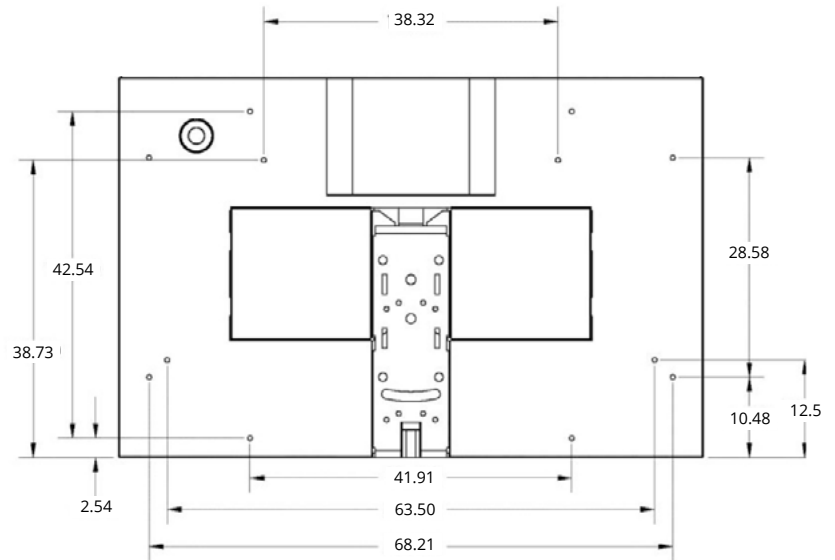
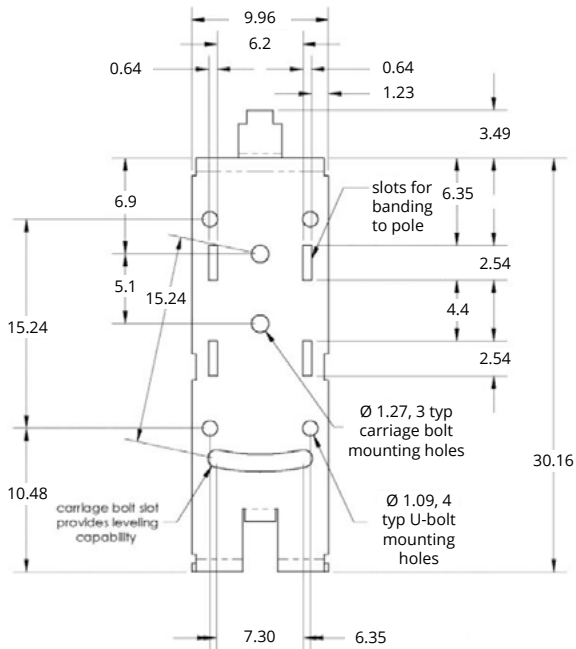

Additional Mounting Provisions:
1/4-20 thread, captive nuts

InstAlert 18 Dimensions

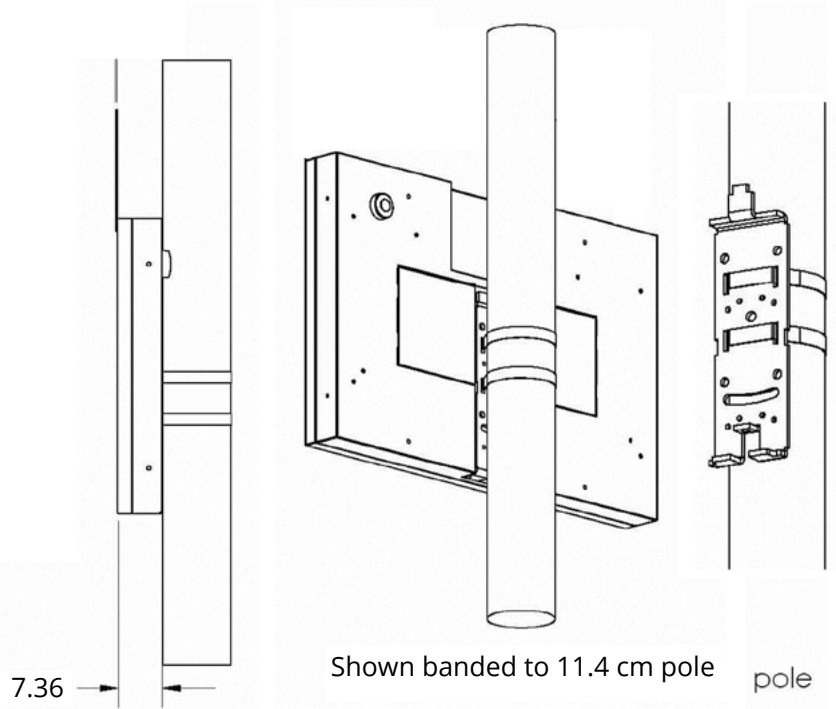
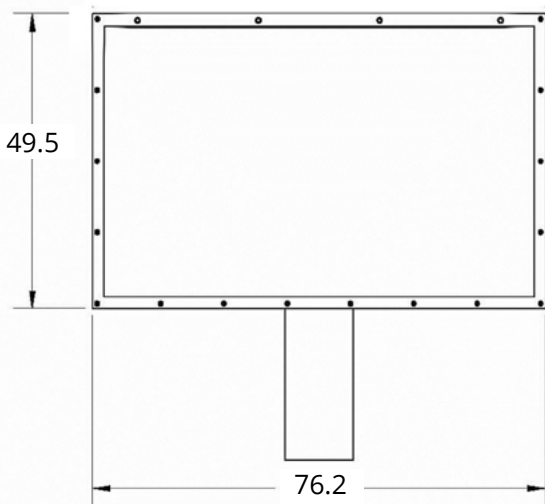

InstAlert 18 with Trailer Mounting Brackets Installed – for Installation on Existing Trailers for Trade-in

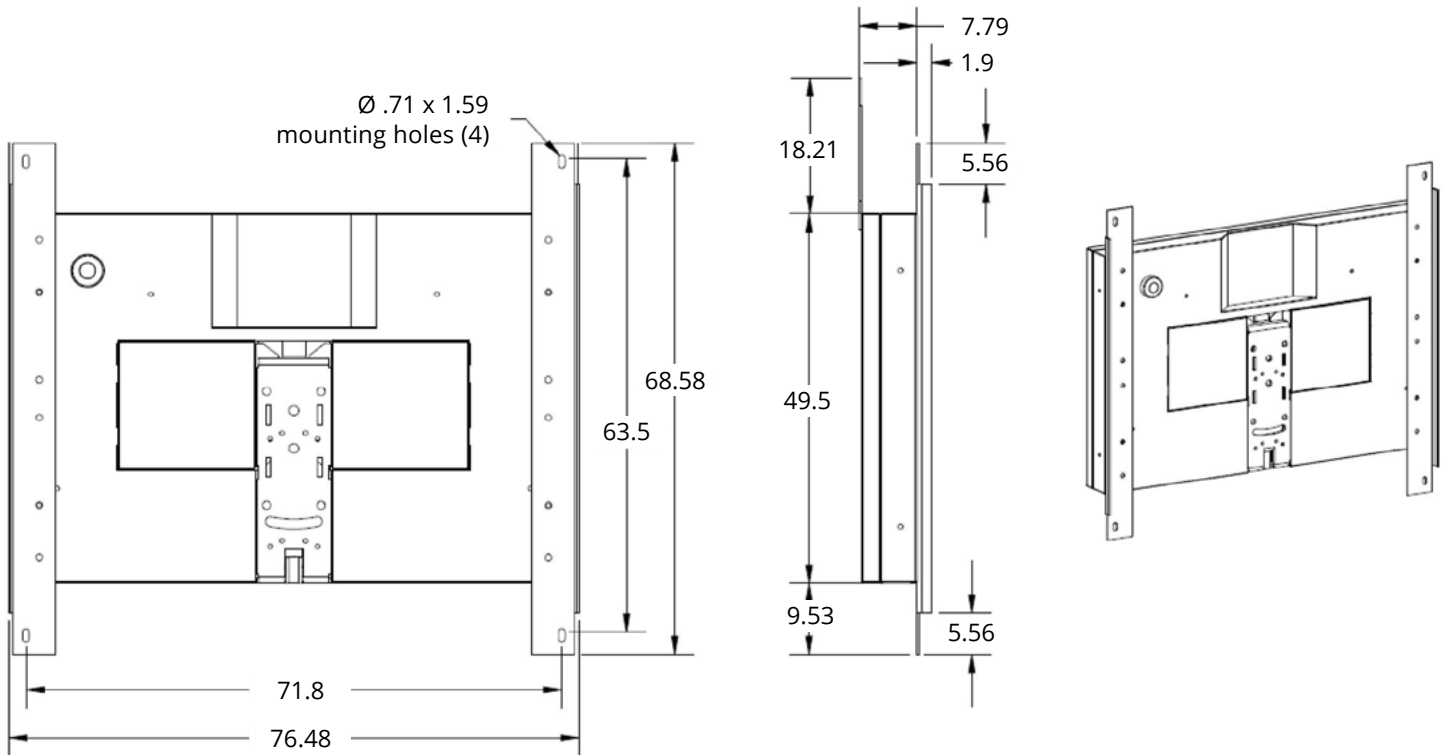

All Traffic Solutions 12950 Worldgate Drive, Suite 310, Herndon, VA 20170

Phone 866.366.6602 | sales@alltrafficsolutions.com | AllTrafficSolutions.com

©All Traffic Solutions

TraffiCloud leverages our patented technology (US Patents 8417442; 8755990; 9070287; 9411893) to deliver unique cloud-based management, features and functionality.